

ZF - SYNCRO: LAYSHAFT ASSEMBLY

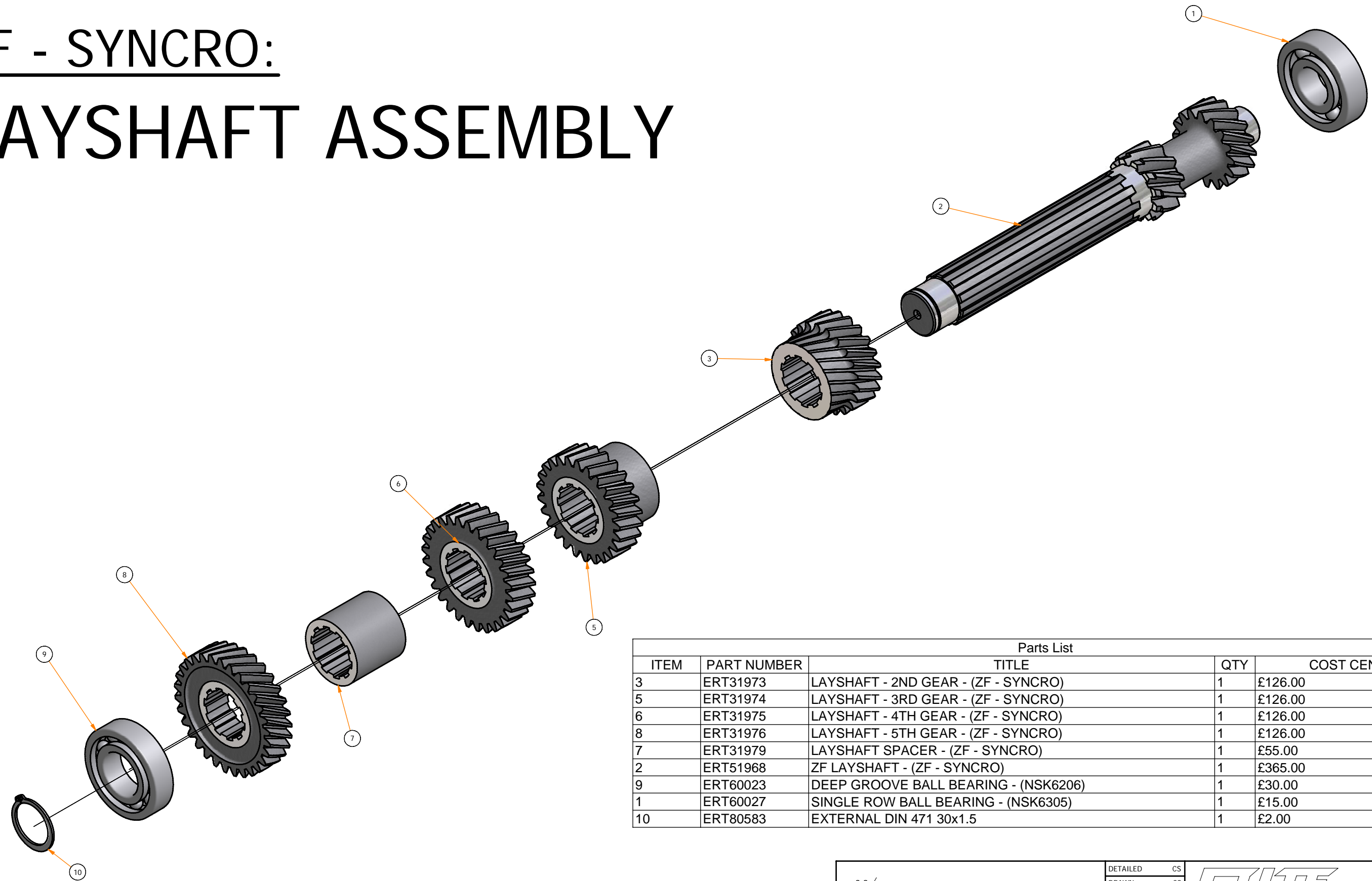

Parts List				
ITEM	PART NUMBER	TITLE	QTY	COST CENTER
3	ERT31973	LAYSHAFT - 2ND GEAR - (ZF - SYNCRO)	1	£126.00
5	ERT31974	LAYSHAFT - 3RD GEAR - (ZF - SYNCRO)	1	£126.00
6	ERT31975	LAYSHAFT - 4TH GEAR - (ZF - SYNCRO)	1	£126.00
8	ERT31976	LAYSHAFT - 5TH GEAR - (ZF - SYNCRO)	1	£126.00
7	ERT31979	LAYSHAFT SPACER - (ZF - SYNCRO)	1	£55.00
2	ERT51968	ZF LAYSHAFT - (ZF - SYNCRO)	1	£365.00
9	ERT60023	DEEP GROOVE BALL BEARING - (NSK6206)	1	£30.00
1	ERT60027	SINGLE ROW BALL BEARING - (NSK6305)	1	£15.00
10	ERT80583	EXTERNAL DIN 471 30x1.5	1	£2.00

CASE HARDEN ALL OVER
TO CASE DEPTH /
SHOT PEEN AFTER HEAT TREATMENT
REM FINISH PRIOR TO FINAL GRINDING
COAT WITH PROTECTIVE OIL AFTER REM FINISHING

3.2 / ALL OVER U.O.S. ALL UNSPECIFIED CHAMFERS TO BE 1x45° ALL UNSPECIFIED RADII TO BE R1	DETAILED CS DRAWN CS APPROVED DATE 28/08/2007	 Gearworks, Salem St., Etruria, Stoke On Trent, ST1 5PR. Tel 01782 280136, Fax 01782 269913, Email contact@eliteracingtransmissions.com.
	UNLESS OTHERWISE STATED TOLERANCES ANGULAR = +/- 0° 00' 0" DIMENSIONS = +/- 0.1MM = +/- 0.004" SURFACE FINISH IN Um 3.2	
REMOVE ALL SHARP EDGES AND BURRS	DO NOT SCALE	DRG. No. ERT92937